

## POLE DR

### Construction:

The DR poles are built from 3 steel pipes, each with a different diameter, that overlap one another on a length of approx. 100 mm, forming a telescopic connection. The diameters become narrower towards the top of the post and vary from  $\varnothing 159$  at the base to  $\varnothing 88$  at the top of the post.

The post (at the base) is welded to the mounting flange. The points of diameter reduction are covered with decorative cast aluminium elements. The flange of the post is masked with a decorative aluminium base.

The aluminium base is fitted with a port that enables access to the inside of the base. The pole has an access door that is closed with the help of a bolt. A mounting rack inside the port enables one to install the connecting panel.

The upper part of the post is a straight pipe cut at an angle of  $90^\circ$  to the axis. Where luminaries are mounted on side-mounted arms rather than at the top of the post, the tip of the post is secured with an aluminium plug. Where an additional arm is to be mounted at the top, the post is fitted with an arm-mounting case.

### Anchorage:

The posts should be mounted on a F150 foundation with a 220x220 spacing of four M24 bolts.

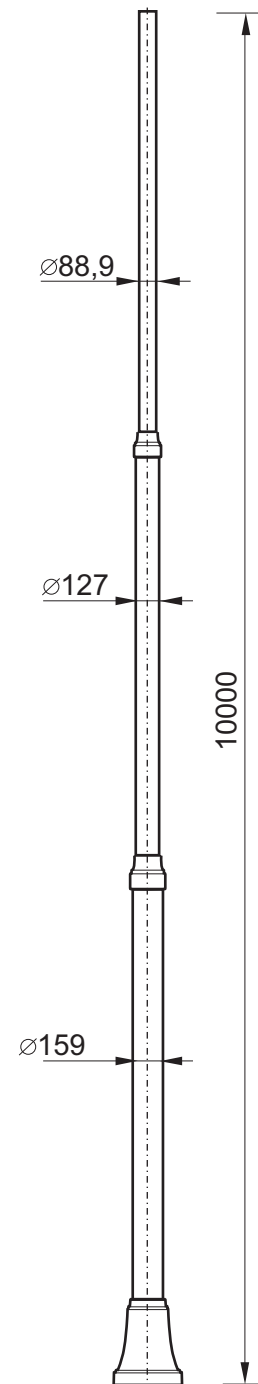

### TECHNICAL INFORMATION:

Maximum side area mounting on the top of pole are  $0,7 \text{ m}^2$  (area simetrically to the pole axis).

Maximum weight on the top of pole **80 kg**.

Parameters calculated for wind area "I" (22m/s) according to PN - EN 40-3-1, PN - EN 40-3-3

### ANCHORAGE:

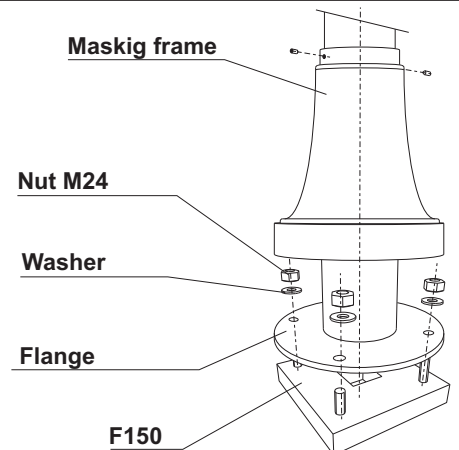
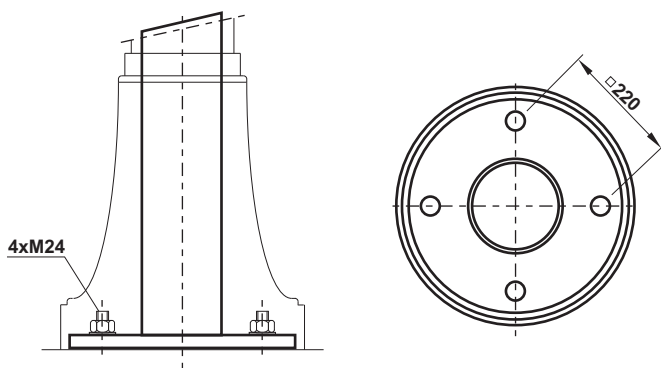

Doc.signature: S-00DR-03

Last revision: 2011.02.09