



art metal

Ul. Jabłoniowa 124, 83-331 Łapino Kartuskie, Poland  
Tel. 0048 58 681 80 78, Fax: 0048 58 681 80 64  
www.art-metal.pl e-mail: biuro@art-metal.pl

# 29 TECHNO LED - PEDESTRIAN CROSSING

## Construction:

The unit consists of a body (1) closed on the top with a bonnet (2) with hinge. Tools are not necessary, to open a luminary unfasten buckles (8). The body is mounted to the pole with adjustable joint (3) which enables to regulate its position. Optical part of the luminary with LED modules (10) and lenses (6) is tightly closed by shade (4) with a frame (5). Power supply (8) is placed in a separate, hermetic compartment. The tightness of the luminary ensure the seals (9).

## Mounting instructions:

- Lead the cable through the joint and place a luminary on the pole or arm (diameter  $\varnothing 60\text{-}\varnothing 76$  mm)
- Tighten the screws and stabilize luminary in a proper position
- Make electrical connections in accordance with the markings. Tighten the cable glands.
- Close the bonnet (2), fasten to the body (1) with buckles (8).
- Angle of the luminary is regulated with a scale on the joint. Tighten the screws to block it on the correct position.

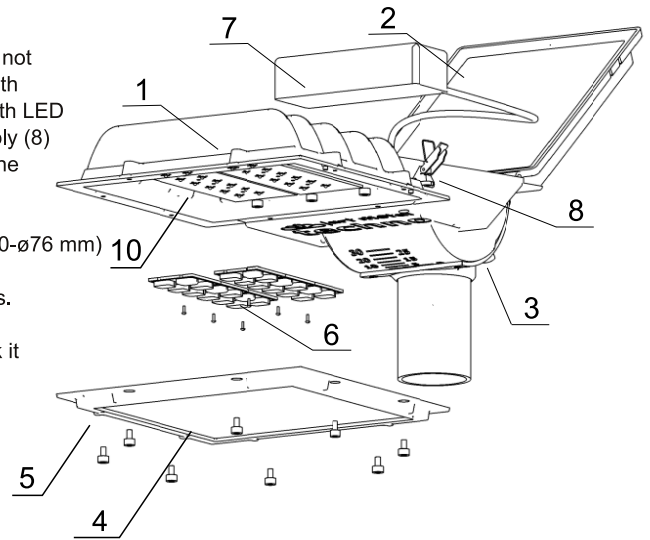

## TECHNICAL DATA:

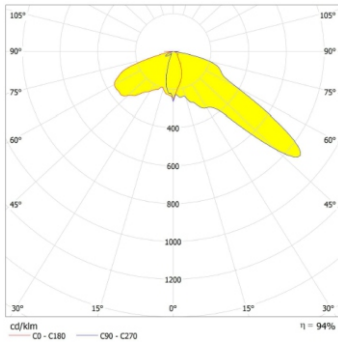

Photometry (polar plot) - PX

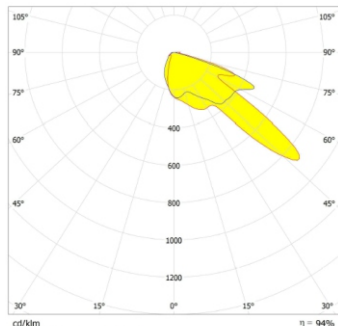

Photometry (polar plot) - PXL

Power: ~230/50Hz

Protective class: I

IP66 - electrical part

IP66 - optical part

IK09

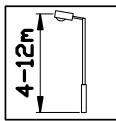

## ELECTRICAL DIAGRAMS:

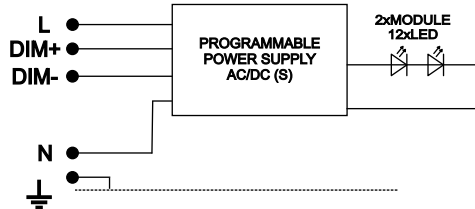

1. Module LED - power supply Lite Prog (S)

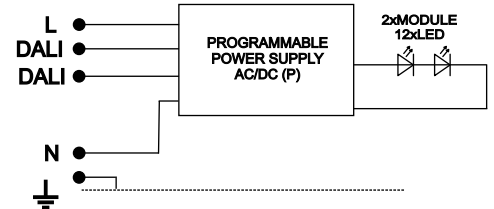

2. Module LED - power supply Full Prog (P)

Type	Typ źródła	Luminous flux [lm]		Weight [kg]	Pn [W]	Luminary dimensions	
		3000K (830)	4000K (840)			L	H
29 L-25W	24-LED-G5	3090	3267	5,5	25		
29 L-32W	24-LED-G5	4017	4247	5,5	32		
29 L-39W	24-LED-G5	4908	5189	5,5	39		
29 L-46W	24-LED-G5	5768	6098	5,5	46		
29 L-54W	24-LED-G5	6600	6979	5,6	54		
29 L-61W	24-LED-G5	7409	7834	5,6	61		



Wind area  
A = 0,14m<sup>2</sup>

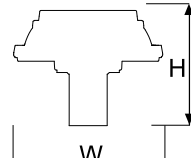

L/W/H  
495/275/210



**WARNING !!** The weight of the unit may slightly differ for individual production batches.

